



MD17E-DSOBV DUSTLESS SANDER SAFETY, OPERATION & MAINTENANCE MANUAL W/PARTS LIST

This unit is intended for commercial use.

Mastercraft

Address: 777 South Street
P.O. Box 2310
Newburgh, NY 12550-0606

TEL:
(800) 835-7812 (845) 565-8850

FAX:
(800) 752-6883 (845) 565-9392

mastercraftusa.com
techsupport@mastercraftusa.com

Read and Follow All Instructions, Warnings & Cautions Before Using This Machine

This floor sander will afford you many years of trouble-free operating satisfaction, provided it is given proper care. All parts have passed rigid quality control standards prior to being assembled to produce the finished product. Prior to packaging, the vacuum was again inspected for assurance of flawless assembly.

Your floor sander is protectively packed to prevent damage in ship-

ping. We recommend that upon delivery, unpack the sander and inspect it for any possible damage. Only a visual examination will reveal damage that may have occurred.

If damage is discovered, immediately notify the transportation company that delivered your sander. As a shipper, we are unable to report claims for concealed damage. You must originate any claims within 5 days.

This manual is for your protection and information. **PLEASE READ CAREFULLY** since failure to follow precautions could result in discomfort or injury.

Treat this floor sander as you would any other high grade precision made product. Dropping, unreasonable bumping across thresholds and other misuses may result in a damaged unit which is not be covered by warranty.

SAVE THESE INSTRUCTIONS

IMPORTANT SAFETY INSTRUCTIONS



WARNING:

RISK OF EXPLOSION

FLOOR SANDING CAN RESULT IN AN EXPLOSIVE MIXTURE OF FINE DUST AND AIR. USE FLOOR SANDER MACHINE ONLY IN A WELL VENTILATED AREA.

To reduce risk of fire, electric shock or injury;
Read all instructions before using this floor sander.

When using this electric floor sander, basic precautions should always be followed, including the following:

- 1) **DO NOT** leave this floor sander plugged in when not in use. Unplug from outlet when not in use and/or before servicing.
- 2) Electric shock could occur if exposed to rain. Store indoors.
- 3) This is **NOT** a toy. Close attention is necessary when used around or near children.
- 4) Use only as described in this manual. Use only manufacturer's recommended attachments.
- 5) **DO NOT** use with damaged cord plug. If the floor sander is not working as it should because it has been dropped, damaged, left outdoors, or dropped into water, contact the manufacturer or authorized service center.
- 6) **DO NOT** handle the plug or operate with wet hands.
- 7) **DO NOT** pull or carry by cord, use power cord as a handle, close a door on cord, or pull cord around sharp edges or corners. **DO NOT** run the floor sander over the cord. Keep cord away from heated surfaces.
- 8) **DO NOT** put any object into motor openings.
- 9) **DO NOT** unplug by pulling on cord. To unplug, grasp the plug, not the power cord.
- 10) Keep hair, loose clothing, fingers and all parts of body away from moving parts.
- 11) **DO NOT** operate where oxygen or anesthetics are used.
- 12) **DO NOT** use around flammable or combustible liquids such as gasoline or use in areas where they may be present.
- 13) **DO NOT** use an extension cord unless absolutely necessary. If an extension cord is used, then wire size must be #14 gauge or thicker and should not exceed 50 feet in length. Use only a three-wire grounded extension cord to ensure grounding protection.
- 14) Replace damaged or worn parts immediately with genuine original equipment parts to maintain safety and to protect your limited warranty.
- 15) Floor sanding can result in an explosive mixture of fine dust and air. Use a floor sanding machine only in a well ventilated area and with the vacuum cleaner hooked up and operating.

GROUNDING INSTRUCTIONS



DANGER:

Improper use of the grounding plug can result in a risk of electric shock.

Electrical equipment must be grounded. If it should malfunction or breakdown, grounding provides a path of least resistance for electrical current to reduce the risk of electric shock. This floor sander is equipped with a cord

having an equipment-grounding conductor and grounding plug. The plug must be inserted into an appropriate outlet that is properly installed and grounded in accordance with all local codes and ordinances.

If repair or replacement of the cord or plug is necessary, **DO NOT** connect the grounded wire to either flat blade terminal. The wire with insulation having an outer surface that is green with or without yellow stripes is the grounding wire.



WARNING:

Improper connection of the equipment-grounding conductor can result in a risk of electric shock. Check with a qualified electrician or service person if you are in doubt as to whether the outlet is properly grounded.

DO NOT modify the plug provided with the equipment. If it will not fit the outlet, have a proper outlet installed by a qualified electrician.

GROUNDING METHODS

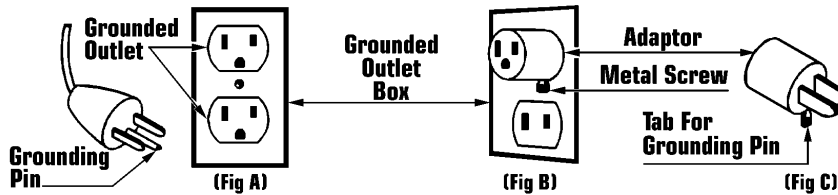

This electric equipment is for use on a nominal 120 volt circuit, and has a grounded plug that looks like the plug illustrated in (Fig A). A temporary adaptor that looks like the adaptor illustrated in (Fig B & C) may be used to connect this plug to a 2-pole receptacle as

shown in (Fig B) if a properly grounded outlet is not available.

The temporary adaptor should be used only until a properly grounded outlet (Fig A) can be installed by a qualified electrician. The green color

rigid ear, lug or the like extending from the adaptor must be connected to a permanent ground such as a properly grounded outlet box cover. Whenever the adaptor is used, it must be held in place by a metal screw.

Note: In Canada, the use of a temporary adaptor is not permitted by the Canadian Electrical Code.

OPERATION INSTRUCTIONS

This floor sander is designed to move from side to side. Raise handle slightly to guide right. As handle is raised higher, the faster it will move to the right. Lower the handle to guide left. Likewise, the more you lower handle, the faster it will move to the left.

Plug in the power cable. With pad driver in position, adjust handle and lock into a comfortable operating position. Place hands on handle grips and squeeze trigger locks beneath grips. This will activate the motor and start pad driver operating.

Begin operating this floor sander at the closest possible point to an electrical outlet and work away from the outlet. This will prevent running over the electrical cord.

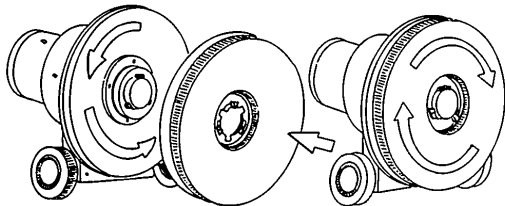

PAD DRIVER INSTALLATION

1) Unplug power cable and **LOCK** handle in upright position.

2) Tilt the floor sander back until the handle is laying on the floor and underside of the machine is fully exposed.

3) Holding the pad driver in both hands straddling the motor with your back to the handle, bend over and fit the three slots of the clutch plate over the three lugs of the drive plate.

4) Turn the pad driver counterclockwise as far as it will go. It is now seated and ready for operation.

To Remove:

Disengage the clutch plate slots from drive plate lugs by turning clockwise.



CAUTION:

Disconnect wall plug before leaving floor sander unattended to prevent accidental startup. **DO NOT** operate this sander without brush or pad driver and pad in place. Never attempt to lock pad driver on floor sander by positioning (**JUMPING**) running floor sander on unattached pad driver.

DO NOT leave a plugged in floor sander unattended.

CHASSIS ASSEMBLY DRAWING & PARTS LIST

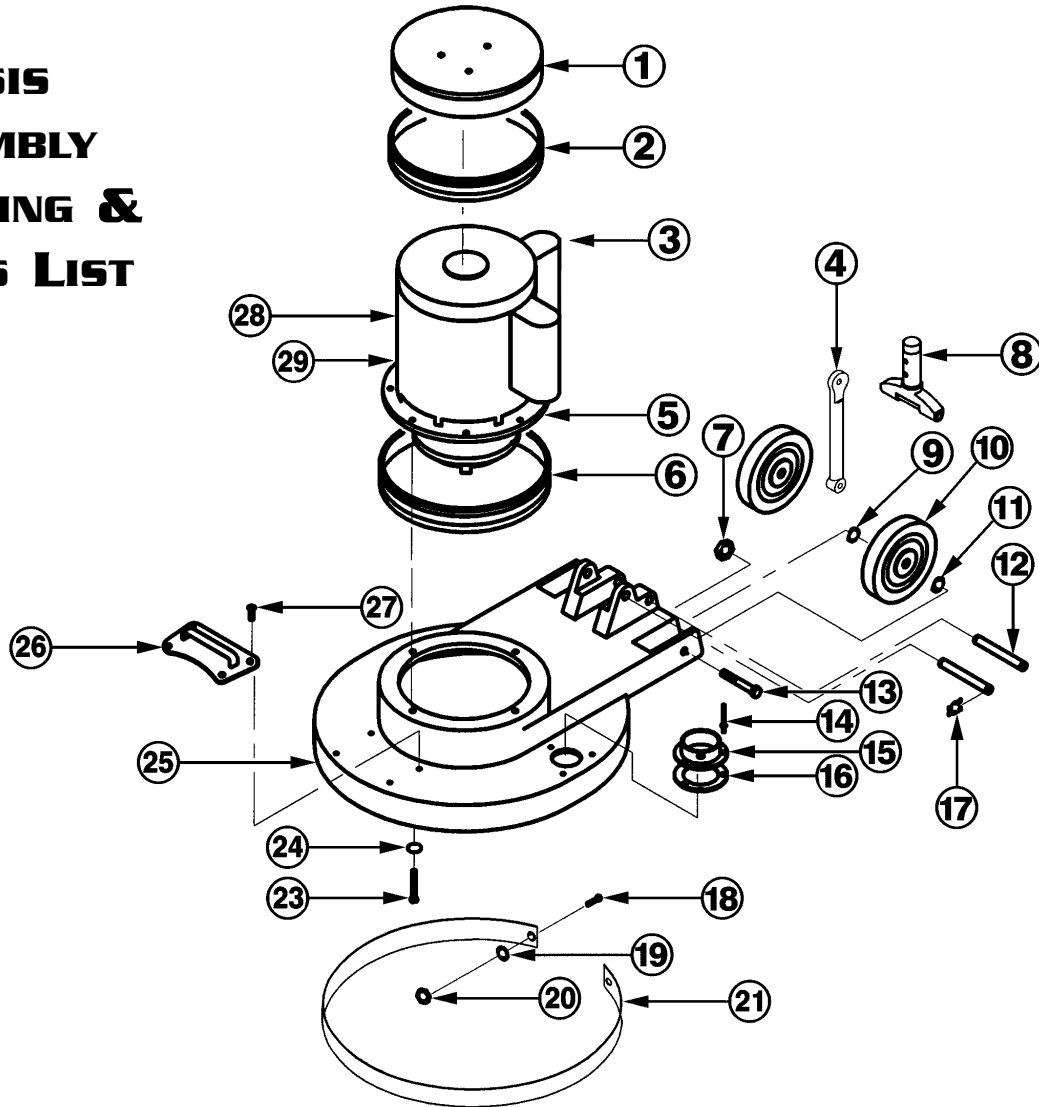

Ref No	Part Description	Qty	Part No	Ref No	Part Description	Qty	Part No
1	Motor Canopy w/Stud	1	353132	15	Hose Connector w/Rivets	1	310999
2	Canopy Bumper	1	441635	16	Circle Gasket	1	320986
3	Capacitor Cover	1	215244	17	E-Clip Retainer	4	368946
4	Strut Support	1	354570A	18	#6 - 32 X .75 Screw	2	482188
5	3 Idler Gear Box Only	1	415642	19	Flat Washer	2	369519
6	Canopy Bumper	1	468258	20	#6 - 32 Hex Nut	2	377171
7	.37-16 Nylok Nut	2	480789	21	Velcro w/Peel & Stick	1	468231
8	Handle Tee	1	234265	23	1/4-20 X 3/4" Screw	4	219290
9	3/8" Flat Washer	2	353221	24	.25 Lockwasher	4	342858
10	1" X 5" Grey Wheel	2	357766	25	17" Apron	1	227587
11	Spring Washer	2	353248	26	Apron Handle	1	463302
12	Metal Straight Pin	2	461776	27	.25-20 X 1/2" Screw	4	479861
13	.37-16 X 2 1/2" Hex Bolt	2	480290	28	1.5 HP Motor	1	415839
14	Pop Rivet	3	318906	29	1.5 HP Motor & Gear Box	1	469580

VACUUM ASSEMBLY DRAWING & PARTS LIST

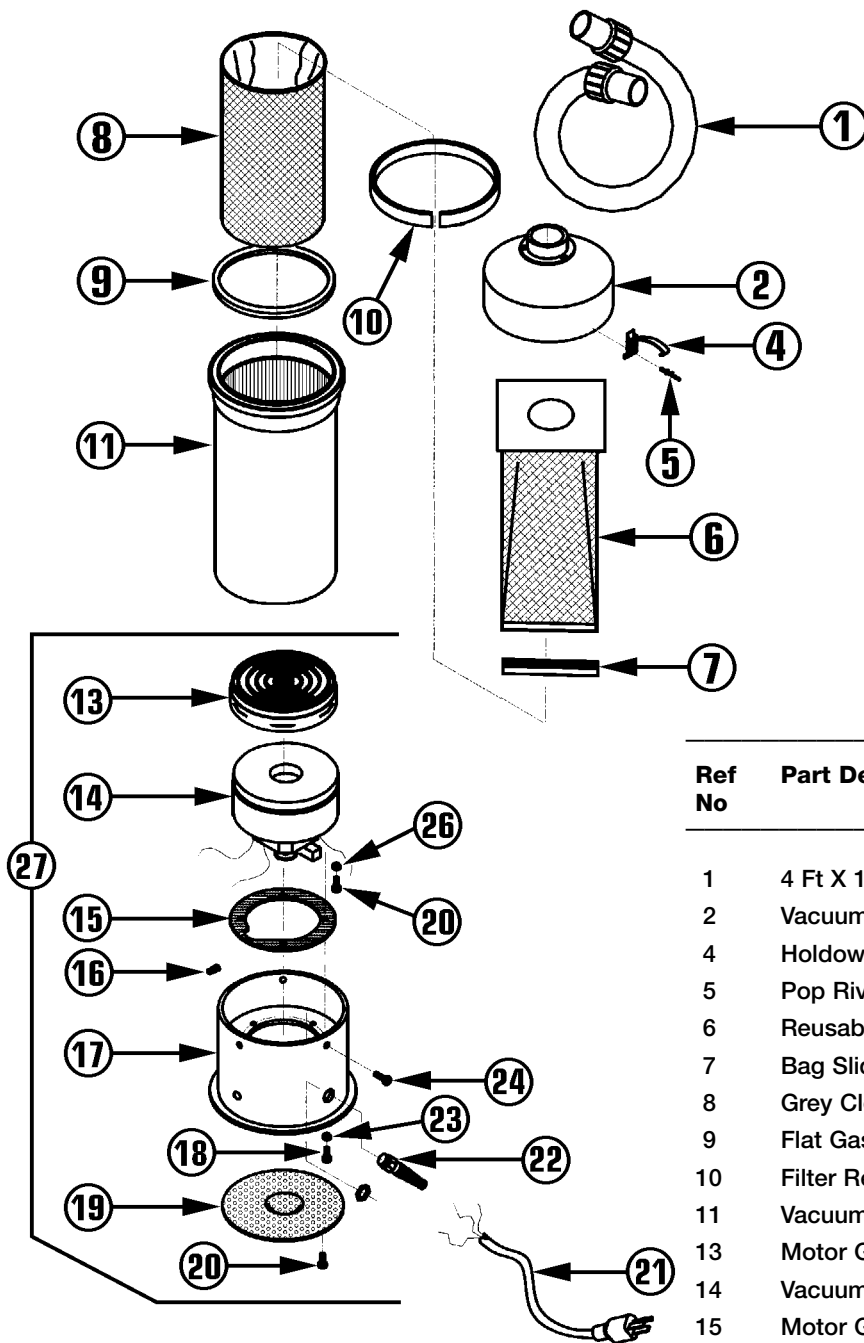

Ref No	Part Description	Qty	Part No
1	4 Ft X 1 1/2" Vacuum Hose Assy.	1	240427
2	Vacuum Cover	1	240389
4	Holdown Clamp	2	447226
5	Pop Rivet	4	214639
6	Reusable Cloth Filter Bag	1	445738
7	Bag Slide Clamp	1	444251
8	Grey Cloth Filter Bag w/Elastic	1	449962
9	Flat Gasket	1	498742
10	Filter Retainer Ring	1	447455
11	Vacuum Body w/Holdown Ring	1	240338
13	Motor Guard	1	422398
14	Vacuum Motor	1	471666A
15	Motor Gasket	2	457752
16	Orange Wire Nut	2	398985
17	Motor Housing	1	240303
18	#10-32 X .65 Screw	4	368385
19	6.25 OD Screen	1	445878
20	#10-32 X .31 Screw	4	368385
21	16/3 Line Cord	1	424463
22	Strain Relief	1	443379
23	Washer	4	369519
24	#1/4- 20 X 1/2" Screw	3	331740
26	#12 Internal Tooth Lockwasher	1	364037
27	Vacuum Motor Base Assembly	1	239291

HANDLE ASSEMBLY DRAWING

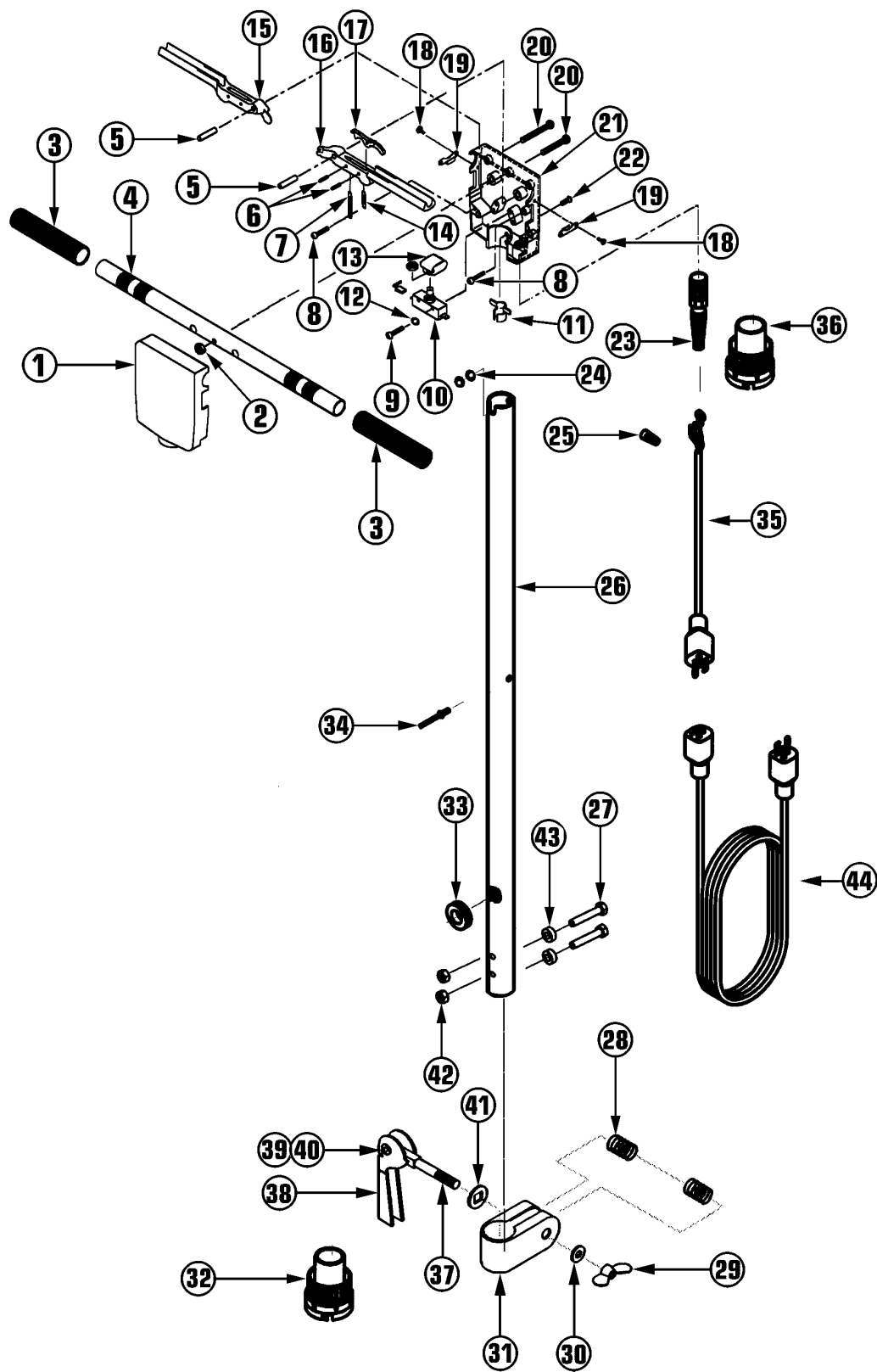

HANDLE ASSEMBLY PARTS LIST

Ref No	Part Description	Qty	Part No	Ref No	Part Description	Qty	Part No
1	Switch Box Cover	1	376647	23	Strain Relief	1	352705
2	#12-24 Nut w/Lockwasher	3	376744	24	#12-24 Hex Nut w/Lockwasher	3	376744
3	Ribbed Handle Grip	2	324744	25	Orange Electric Wire Connector	1	398985
4	Handle Bar	1	376612	26	39" Handle Tube	1	353086
5	1/4 X 1 1/4" Trigger Pin	2	376701	27	0.31 - 18 X 1 2/3" Hex Screw	2	232408
6	Roll Pin	4	383139	28	Coiled Spring	2	367184
7	Extension Spring	2	376671	29	Wing Nut	1	380490
8	#8-32 X 3/8" Screw	2	367389	30	3/8" Flat Washer	1	353221
9	#6-32 X 1" Switch Screw	2	335576	31	U-Clamp	1	376051
10	25 AMP Micro Switch	1	469629	32	1 1/2" Swivel Hose Connector	1	349445
11	Cord Clamp	1	342890	33	Plastic Grommet	1	477885
12	#6 Internal Tooth Washer	2	355224	34	Pop Rivet	8	318892
13	Leaf Spring	1	335584	35	24" 14/3 Power Cord	1	374091
14	Trigger Lock Spring	2	383147	36	1 1/2" Swivel Hose Connector	1	349445
15	Plastic Trigger	2	385654	37	.37-16 X 3.37 Bolt	1	380504
16	Trigger Kit	2	386839	38	Clamping Lever	1	380520
17	Trigger Lock	2	390119	39	Lever Pin	1	382434
18	#6-32 X 1/4" Screw	4	349402	40	Metal Cap	1	380555
19	Reinforced Plate	2	387169	41	Sq Hole Flat Washer	1	382426
20	#12-24 X 1 7/16" Screw	5	376760	42	.31 - 18 Hex Lock Nut	2	354791
21	Switch Box	1	376620	43	.319ID, .625 OD, .250L Spacer	2	232394
22	#12-24 X 1/2" Screw	2	312746	44	25 Ft 14/3 Extension Cord	1	373990

HANDLE ADJUSTMENT



WARNING:

To avoid damage to the equipment or personal injury:
NEVER turn sander ON with the handle in locked upright position.
NEVER make any handle adjustments unless the motor/chassis base is sitting upright, flush to the floor.

The handle adjustment is controlled by a lever in the rear of the machine at the base of the handle.

To Adjust The Handle:

- 1) Pull up on the upper portion of the lever to release handle.
- 2) Pull the handle back to the appropriate operating position.

- 3) Step down on the lever to lock the handle into position.

When transporting or attaching the pad driver the handle **MUST** be **LOCKED** in the upright position.

CARE & MAINTENANCE

1) When not in use, power cord should be wrapped around cord hooks for storage.

2) With the floor sander unplugged, check the power cord for any breaks in the wire. Breaks will most likely occur near the plug or switch. Any breaks should be repaired or replaced immediately.

Read this manual completely before operating the floor sander. It is important to follow instructions in this manual to prevent the possibility of injury or damage to the user and/or sander.

3) After each use, wipe off all of the polished and painted areas with a clean cloth.

4) When sander is not in use, remove pad driver, wrap power cord around cord hooks and store in a dry area.

If the machine wobbles or vibrates:

When using floor pads, to achieve the best results use clean pads frequently, changing them as they load up. Always remove pad and driver assembly when storing the sander.

A) Adjust by turning pad $\frac{1}{3}$ turn, then reinstall on sander.

B) Inspect the pad driver for warpage or out of round. Lay floor sander down on handle with pad driver in place. With sander running, observe if pad driver appears to wobble or is out of round. Replace if this problem occurs.

TROUBLE SHOOTING GUIDE



WARNING:

Always disconnect power cable from electrical outlet when working on the floor sander

PROBLEM: Motor won't run.

Possible Cause

1. Blown fuse or tripped circuit breaker
2. Defective switch.
3. Defective power cord.

Possible Solution

1. Replace fuse or reset circuit breaker.
2. Replace switch.
3. Replace power cord.

PROBLEM: Floor machine runs slow.

Possible Cause

1. Low line voltage.

Possible Solution

1. If voltage is under recommended minimum, check size of wiring from main switch. If okay, contact power company.

PROBLEM: Noisy machine.

Possible Cause

1. Defective motor or gear box.

Possible Solution

1. Contact the manufacturer or authorized service center.