



DEBRIS MASTER™ ELECTRIC INDUSTRIAL LITTER VAC OPERATION MANUAL

This litter vac will afford you many years of trouble-free operating satisfaction, provided it is given proper care. All parts have passed rigid quality control standards prior to their being assembled to produce the finished product. Prior to packaging, your unit is again inspected for assurance of flawless assembly.

This litter vac is protectively packed to prevent damage in shipment. We recommend that upon delivery, unpack the unit and inspect it for any possible damage. Only a visual examination will reveal damage that may have occurred.

If damage is discovered, immediately notify the transportation company that delivered your unit. As a shipper, we are unable to report any claim for damage. You must originate any claim within 5 days of delivery.

This manual is for your protection and information. PLEASE READ CAREFULLY since failure to follow precautions could result in discomfort or injury. Read this manual completely before operating this litter vac. It is important to follow instructions in this manual to prevent the possibility of injury or damage to the user and/or litter vac.

PLEASE READ CAREFULLY BEFORE OPERATING

SAVE THESE INSTRUCTIONS



Address: 777 South Street, P.O. Box 2310
Newburgh New York 12550-0606
TEL: (800) 835-7812 ■ (845) 565-8850
FAX: (800) 752-6883 ■ (845) 565-9392
URL: www.mastercraftusa.com
E-mail: techsupport@mastercraftusa.com

LITTER VAC SPECIFICATIONS



- ◆ **Power:**
Electric 1.5 HP
- ◆ **Involute Housing:**
6³/₄" High X 18³/₄", all 14 gauge welded steel reinforced at all stress points. Mounted parallel to wheel base, provides extra vacuum.
- ◆ **30" Intake:**
Tapered intake for suction beyond intake width. 3° taper generated from center of intake mouth central to involute housing.
- ◆ **Booster Baffle:**
Directly under involute housing (16 gauge. steel), cylindrical baffle to pick-up heavier, denser debris (i.e. nails, washers, broken glass, bolts).
- ◆ **Steel Impeller:**
12" diameter X 4³/₄" high welded and balanced 1/4" thick.
- ◆ **Impeller Shaft Guard:**
Prevents string, wire banding straps from wrapping around and binding motor shaft.
- ◆ **Triple Deflection Deflector Baffle:**
Designed to protect operator and collection bag from heavy or sharp objects
- ◆ **Rear and Front Wheels:**
10" Dia Semi-Pneumatic Rear Wheels (2) and 3¹/₂" Dia 360° Swivel Front Wheel, for quick and easy maneuverability.
- ◆ **Remote Control Throttle:**
Mounted on handle of machine for quick and easy starting, stopping and regulation of motor RPM.
- ◆ **11 Cu. Ft. Filter Bag:**
Hi-performance collector filter bag with 55" zipper that opens bag for fast emptying.
- ◆ **Bag Dolly Assembly:**
Attached to rear axle of sweeper with its own swivel support caster to carry the weight of the bag as it fills.
- ◆ **Handle:**
1" dia chrome plated tubular steel.

Dolly Assembly

Clamps over axle for easy attachment and use.

Handle Assembly

See Instructions below.

Remote Control

Install on engine first. See engine instructions sheet.

Attach control lever to top of handle with screws provided. Use clips to hold control against handle.

Work control for ease of operation and see that speed control on engine moves to both limits.

Tighten inner control wire clamp, cut off excess and blend under.

Engine:

READ manual before starting engine.

Bag Installation

1) Slip filter bag neck over Deflector Baffle and into the "U" channel of the housing exhaust and tighten.

2) Clamp should be on the right side of tip channel.

CAUTION:

Make sure the bag **DOES NOT** come into contact with the muffler.

If it does, and the bag is installed correctly, rotate the engine counterclockwise.

The bag is designed for use with the Dolly. When using outside, open side vent zipper to get rid of excess dust and maintain a constant flow of air.

When not practical to exhaust dust close zipper and clean bag often.

KEEP BAG CLEAN

Dry out when wet to avoid rotting.

INSTALLATION INSTRUCTIONS

HANDLE ASSEMBLY INSTRUCTIONS

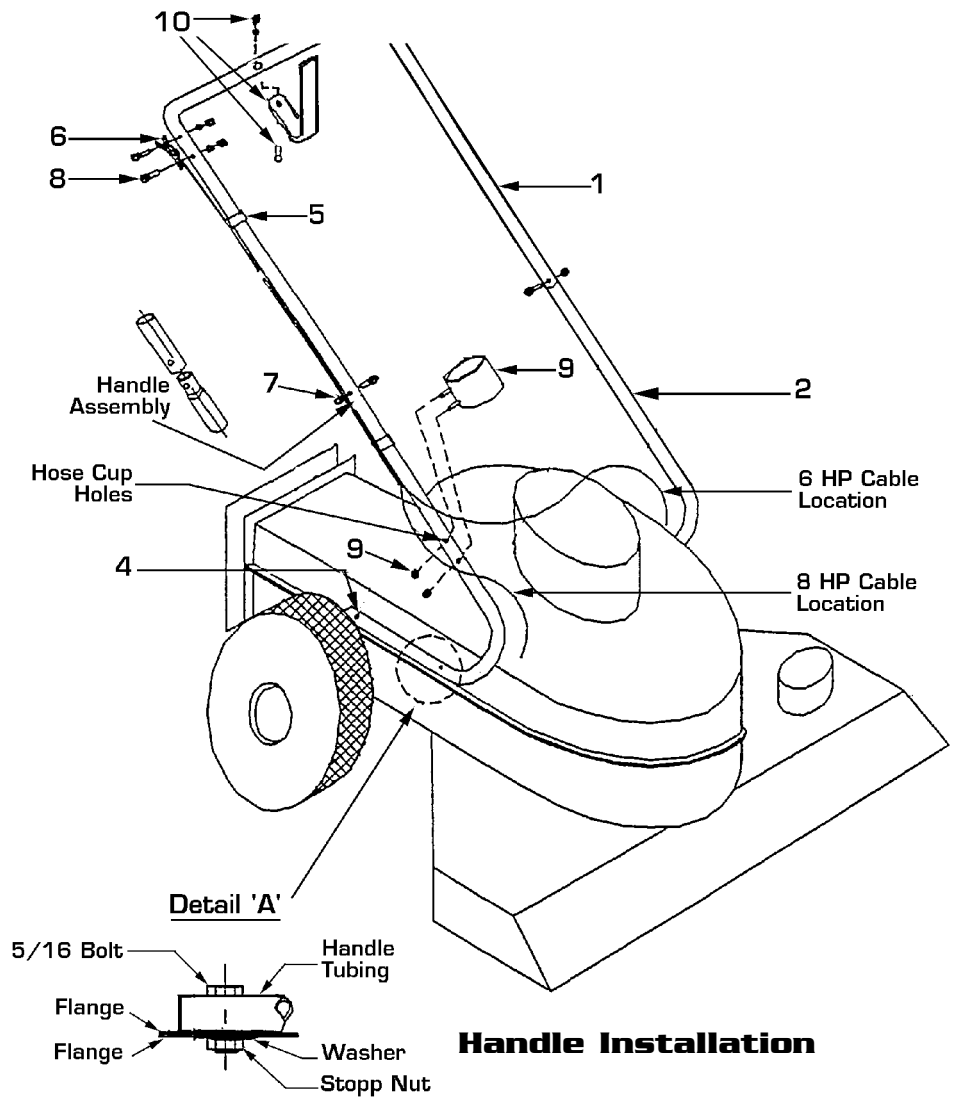

Handle Installation

- 1) Hold Handle Legs (#2) in place and install with bolts, washers and stopp nuts. (See Detail 'A')
- 2) Install Handle 'U' (#1) making sure Remote Control holes on 'U' are on right side as you push the machine.
- 3) **DO NOT** tighten until Handle 'U' (#1) has been assembled onto Handle Legs (#2).

Parts List

Ref	Qty	Description
1	1	Handle 'U'
2	2	Handle Leg
4	4	5/16" Nylon Stopp Nut
5	2	Cable Clip
6	1	Throttle Control
7	2	5/16-18 1 1/4" Nuts
8	1	10-24 X 1 1/4" Screws
9	1	Hose Cup w/Nuts (2)
10	1	Hose Bracket, 5/16 Bolt Nut & Lockwasher

HOSE ASSEMBLY

Hose Assembly

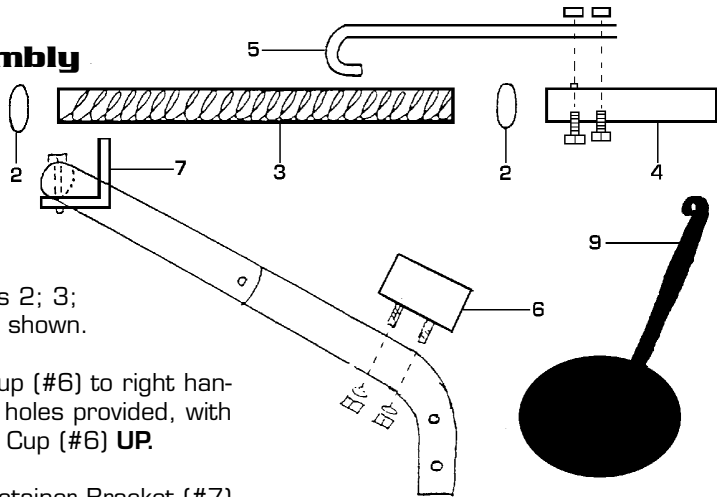

1) Assemble parts 2; 3; 4; 5; in the order shown.

2) Attach Hose Cup (#6) to right handle leg at the two holes provided, with open end of Hose Cup (#6) UP.

3) Attach Hose Retainer Bracket (#7) to center of 'U' Handle at hole provided to hold hose in place.

4) The bracket is attached to underside of 'U' pointing upward.

5) Install Hose Assembly to Intake Port on deck of unit.

6) Drape hose around Retainer Bracket (#7) and place Nozzle in Hose Cup (#6).

Parts List

Ref	Qty	Description
2	2	Hose Clamp
3	1	10 Ft Flexible Hose
4	1	Hose Nozzle
5	1	Cane Handle
6	1	Hose Cup
7	1	Hose Retainer Bracket
9	1	Hose Baffle Plate

Deflector Baffle Installation

Install by sliding deflector sideways in top and bottom exhaust channels as shown.

Press fit is required, use mallet to slide to center of exhaust outlet.

If deflector does not fit tightly in channels remove and bend bottom edge up slightly.

With the Deflector in place the bag may then be attached. The bag fits over both channels.

Care should be taken not to push the handle down towards the floor further than is necessary as it will force the deflector against the dolly and peel it off.

Deflector Baffle

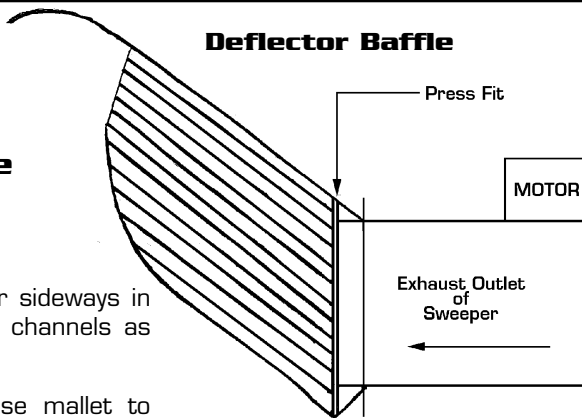

Deflector Applications

- ◆ Used to provide extra protection for bags when recovering heavy or sharp debris.
- ◆ Especially necessary when using the booster baffle.
- ◆ Very helpful in providing a dead air space when recovering excess dust.
- ◆ Prolongs emptying cycle of bag during heavy dust conditions (merely shut off machine and shake down bag).

CAUTION:

DO NOT run this machine without Deflection Baffle Installed.

DEFLECTOR Baffle Installation

OPERATION INSTRUCTIONS

Cleaning Operation

Push litter vac over area to be cleaned.

Throttle setting and speed of work depend upon debris to be cleaned and frequency of cleaning.

Run engine at **slowest speed possible** and still pick up debris.

When encountering large debris, push down on handle and the litter vac will pickup large debris such as milk cartons, beer cans, paper cups and plates, etc.

Do's & Don'ts

- Don't** Run litter vac without deflector baffle installed properly.
- Don't** Run the litter vac without the bag attached.
- Don't** Try to pickup cans larger than large beer cans.
- Don't** Add oil to gas.
- Don't** Pickup large pieces of rope.
- Do** Clean bag often.
- Do** Change oil and filter often.

AUTOMATIC HOSE BAFFLE

Automatic Hose Baffle

T-Handle locked in open position assures maximum vacuum for wide area ground cleaning. Engagement of AB-OO lever to close position will maximize involute suction to hose.

Hose may be used to vacuum without closing baffle plate.

To Close Baffle Plate

Push down on T-handle to release lock and rotate clockwise.

To Open Baffle Plate

Rotate T-handle counterclockwise and baffle plate will automatically lock in open position.

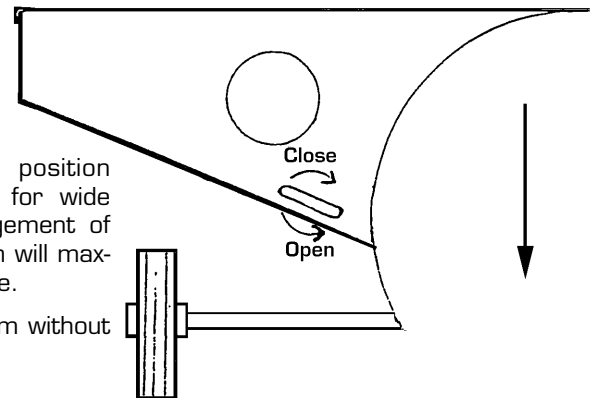

Note: Pull litter vac backwards before rotating the T-Handle to re reverse front wheels allowing full movement of baffle plate

CAUTION:

Shut OFF machine before engaging or disengaging hose baffle.

Maintenance

NONE - except for normal engine care and oil wheels.

To change oil:

Just remove oil drain cover and tilt unit to drain into large container. No need to reach under machine to drain oil.

To Inspect or Work on Engine:

Eight nuts may be removed and the complete powerpac - Engine, motor plate and impeller are removable as a unit.

CAUTION:

Always remove spark plug wire before inspection or working on engine.

MAINTENANCE

LIMITED WARRANTY

Mastercraft warrants new machines against defects in material and workmanship under normal use and service to the original-end user purchaser. The warranty period is subject to the conditions below:

Registration of Warranty:

The warranty commences on the date of purchase by the original end user from an authorized Mastercraft distributor, subject to proof of purchase. The warranty registration card must be completed immediately and returned at the time of purchase. If proof of purchase cannot be identified, the warranty starts from the date of sale to the authorized Mastercraft distributor. Parts replaced or repaired under warranty are warranted for the remainder of the original warranty period.

Warranty:

One year warranty against mechanical defect and workmanship, except for bags, fuel tubes, brass nipples and rubber parts. Should defects develop, parts must be returned to our factory prepaid for inspection. Mastercraft will not be responsible for repairs made outside our factory without authorization.

Engine Warranty:

Engine warranty of One Year is carried by the engine manufacturer and his dealers on Industrial/Commercial engines ONLY. A 90 day warranty is offered on standard engines. Engines may be sent any local Briggs & Stratton dealer for repair or service

Warranty is null and void for the following:

- 1) Damage, defects, malfunctions or other failures caused by not using the electric current indicated on the spec plate.
- 2) Damage or defect caused by accident; misuse; neglect; abuse; fire; etc. This includes use of incompatible or corrosive chemicals or overloading of capacity.

3) Failure due to lack of proper maintenance and care (including cleaning).

4) Any design alterations, adjustments and/or repairs performed on the equipment by an organization not authorized or specified by Mastercraft Industries.

5) Use of parts not approved by Mastercraft Industries will void all warranties.

6) If machines are used for a purpose other than that which it was intended.

7) Damage in transit.

Stated Warranties:

Stated warranties are in lieu of all other warranties, expressed or implied. Any statutory implied warranties, including any warranty of merchantability or fitness for a particular purpose, are expressly limited to the duration of the written warranty. Mastercraft will not be liable for any other damages, including but not limited to indirect or special consequential damages arising out of or in connection with the furnishing, performance, use or inability to use the machine. This remedy shall be the exclusive remedy of the buyer. The warranty is limited to the warranty.

Warranty Claim Procedure:

If a difficulty develops during the warranty period, contact the authorized Mastercraft distributor from whom the unit was purchased. Mastercraft may elect to require the return of unit or components to validate the claim. Any defective part to be returned must be shipped freight pre-paid to an authorized Mastercraft Distributor/Service Center.

Note: Because these machines are intended for commercial and/or industrial use the warranty is limited and not applicable to persons purchasing or using this equipment for rental, personal, family or household use in which case the 90 day rule applies.