

# **SAFETY, OPERATION MANUAL & PARTS LIST**



** DYNNAVAC®**

**DYN-2220 &  
DYN-2320**

**DYNAVAC CONCRETE  
INTERMITTENT DUTY  
DRY VACUUMS**

This unit is intended for commercial use.

**READ & FOLLOW ALL  
INSTRUCTIONS, WARNINGS & CAUTIONS  
BEFORE USING THIS VACUUM.**

## **PLEASE READ CAREFULLY BEFORE OPERATING**

This vacuum will afford you many years of trouble-free operating satisfaction, provided it is given proper care. All parts have passed rigid quality control standards prior to their being assembled to produce the finished product. Prior to packaging, your vacuum was again inspected for assurance of flawless assembly.

This vacuum is protectively packed to prevent damage in shipment. We recommend that upon delivery, unpack the vacuum and inspect it for any possible damage. Only a visual examination will reveal damage that may have occurred.

If damage is discovered, immediately notify the transportation company that delivered the vacuum.

As a shipper, we are unable to report any claim for damage. You must originate any claim within 5 days.

This manual is for your protection and information. **PLEASE READ CAREFULLY** since failure to follow precautions could result in discomfort or injury. Read this manual completely before operating this vacuum. It is important to follow the instructions in the manual to prevent the possibility of injury or damage to the user and/or vacuum.

Treat your vacuum cleaner as you would any other high grade precision made product. Dropping, unreasonable bumping across thresholds and other misuses may result in a damaged unit that will not be covered by warranty.

**SAVE THESE INSTRUCTIONS**

# **IMPORTANT SAFETY INSTRUCTIONS**

## **WARNING:**

To Reduce the Risk of Fire, Electric Shock or Injury:  
Electric shock could occur if used on wet surfaces.  
DO NOT expose to rain. Store indoors.

When using this vacuum basic precautions should always be followed, including the following:

- 1) DO NOT leave the vacuum when plugged in. Unplug from the outlet when not in use and before servicing.
  - 2) This Vacuum is designed for intermittent use, i. e. not more than 2 hours continuously. If you are unsure about your application consult your dealer.
  - 3) This is NOT a toy. Close attention is necessary when used around or near children.
  - 4) Use only as described in this safety manual. Use only manufacturer's recommended attachments and accessories.
  - 5) DO NOT use this vacuum with a damaged cord or plug. If the vacuum is not working as it should, because it has been dropped, damaged, left outdoors or dropped into water, contact an authorized service center or factory.
  - 6) DO NOT unplug the vacuum by pulling on the cord. To unplug, grasp the plug, not the cord.
  - 7) DO NOT pull or carry by the cord, use cord as a handle, close a door on cord, or pull cord around sharp edges and corners. DO NOT run vacuum over cord. Keep cord away from heated surfaces.
  - 8) DO NOT handle the vacuum's plug with wet hands.
  - 9) Keep hair, loose clothing, fingers, and all parts of the body away from openings and moving parts.
  - 10) DO NOT put any objects into openings. DO NOT use with any opening blocked; keep free of dust, lint, hair and anything that may reduce air flow.
  - 11) DO NOT pick up anything that is burning or smoking, such as cigarettes, matches, or hot ashes
  - 12) DO NOT use without the cloth filter assembly in place.
  - 13) DO NOT use the vacuum for removal of liquids or any volatile viscous, flammable or explosive media or use in areas where they may be present.
  - 14) DO NOT use where anesthetics and oxygen are used.
  - 15) Turn OFF all the controls before unplugging
  - 16) DO NOT use an extension cord unless absolutely necessary. If an extension cord is used, then wire size must be #12 or larger and should not exceed 50 feet in length. The extension cord must be a three-wire type to insure grounding protection.
  - 17) Replace damaged or worn parts immediately with genuine original equipment parts to maintain safety and to protect your limited warranty.
- This vacuum must be connected to a properly grounded outlet only. (See grounded instructions)
- When not in use the power cord should be wrapped around the handle for storage.

## **INTENDED USE OF THIS VACUUM**

This vacuum has been specifically designed to clean up concrete dust. Special filters reduce the incidence of airborne dust that would be created by other methods of cleaning.

DO NOT at any time attempt to substitute, remove, bypass filters in the vacuum.

**CAUTION:** A dust mask should be worn when changing the filters.

When installing a new filter use only the manufacturer's approved vacuum filter.

Before attempting to use or before cleaning with this vacuum, be sure that you fully understand the instructions for installing or cleaning the filter.

DO NOT use this unit until the owner's manual has been read. Improper use could cause damage to the vacuum or special filters employed.

# OPERATION INSTRUCTIONS

## CAUTION:

The electrical service at the installation site **MUST** supply the voltage indicated on the vacuum's spec plate. Operating at an incorrect voltage may damage the machine.

**NOTE:** A qualified electrician in accordance with the National Electric Code and all local codes should perform all wiring and/or electrical adjustments during installation and servicing.

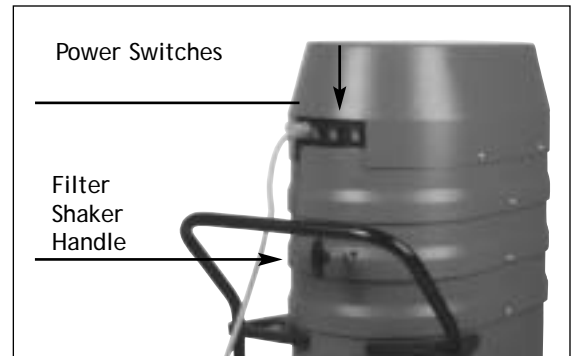
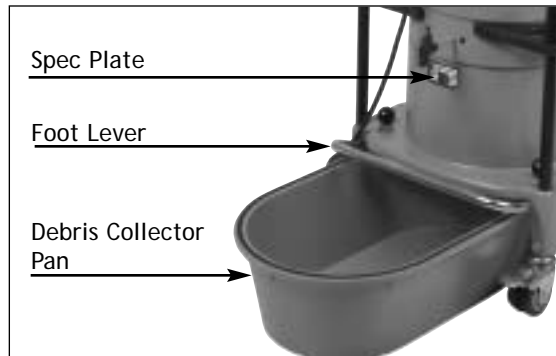

- 1) Pull up on the foot level to release the dustpan.
- 2) Check to see that the debris collector pan is completely empty. Empty the pan if necessary and replace.
- 3) Plug the vacuum to the proper power source, as indicated on the spec plate.

- 4) Turn **ON** the power switches **ONE AT A TIME**.
- 5) After each use, shake the filter using the filter shaker handle and empty the debris collector pan.

## CAUTION:

**NEVER** operate the vacuum cleaner without the filter assembly properly installed. Motor damage, loss of operating efficiency and re-circulation of material into the work area will take place.

# INNOVATIVE MODULAR DESIGN

The filter system in this vacuum is a super-long life, oversize, single-element primary filter that is 99.9% efficient @ 0.5 micron. In normal operation with periodic cleaning the filter may never need replacing for the life of the vacuum.

- 1) **Sound Suppression**  
Inclusive for quiet operation.
- 2) **Individually Motors**  
Cooled motor bearing longevity
- 3) **Cast Composite**  
Fiberglass reinforced compression
- 4) **Long Life Filters**  
Oversized for outstanding micro-particle capture.
- 5) **Modular Oval Construction**  
Gives maximum design flexibility.
- 6) **Cast Deflector**  
Knock materials out of the airstream
- 7) **Counterbalanced Bases**  
Tip resistant with low level hose inlets
- 8) **Heavy Duty Casters**  
Two Front Swivel  
Two Rear Locking
- 9) **Collector Pan**  
Lever actuated drip down for easy emptying
- 10) **External Shaker**  
Manual control for cleaning filters

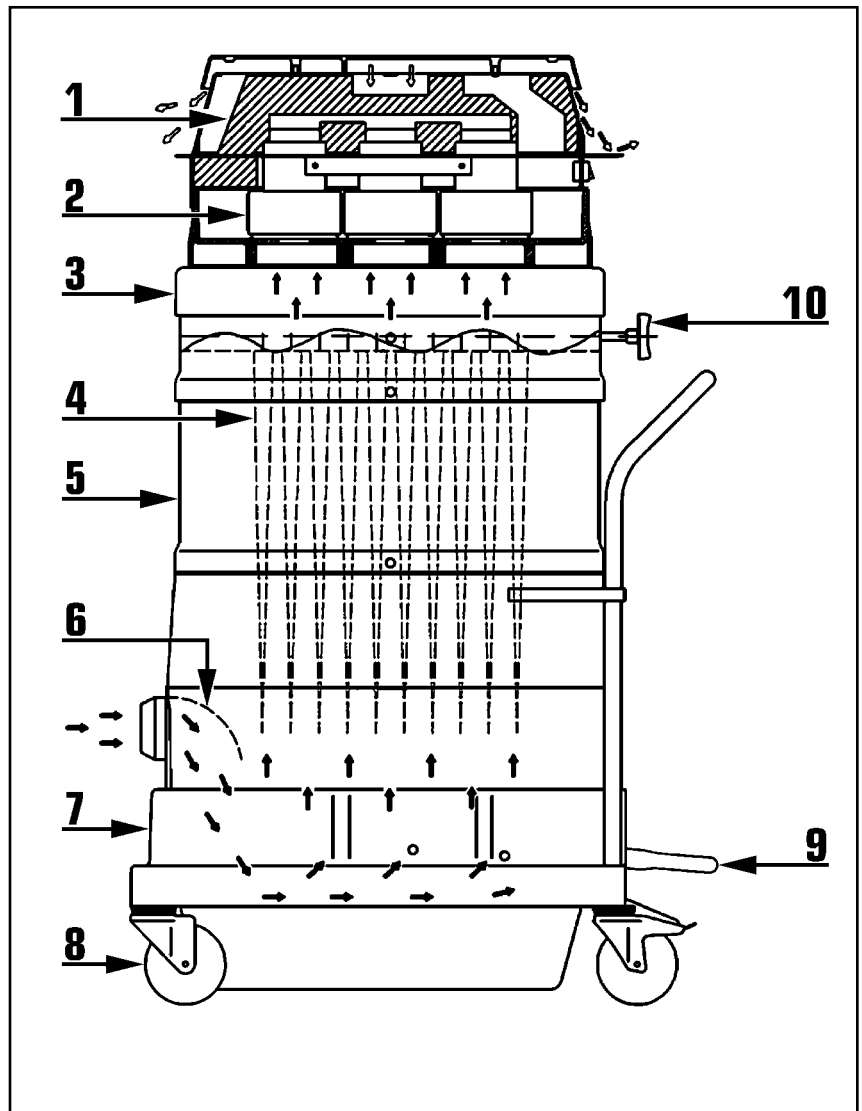

# **CLEANING/INSPECTION FILTER & DEBRIS PAN**

## **CAUTION:**

Clogged material **MUST** only be removed by hand.  
**DO NOT** use an object to dislodge material may tear the filter.  
Consult your representative if material blockage is excessive.

- 1) Turn OFF the vacuum.
- 2) Knock debris off the filter using the filter shaker handle.
- 3) Pull up on the foot lever to release the debris collector pan. Remove and empty if necessary.
- 4) Lock the rear casters.
- 5) Carefully tip vacuum back onto the push handle.
- 6) Remove any material that has collector between the filter pleats, by hand **ONLY**.
- 7) Inspect the filter pleats tears and material blockage.
- 8) Carefully tip the vacuum back onto the casters and replace the debris collector pan.

# **FILTER REMOVAL**

## **CAUTION:**

A dust mask should be worn when changing the filters.

- 1) Follow the filter inspection procedure to determine if removal is necessary.
- 2) Turn the machine **ON** then block the inlet with a flat and rigid material to place the machine under vacuum pressure.
- 3) Remove screws from the filter housing with a 5/32 hex-wrench.
- 4) Turn the vacuum **OFF** and disconnect the power source.
- 5) Separate the motor deck from the housing then disconnect the motor deck ground wire from the subsequent assembly via the push-on terminal.
- 6) Remove the motor deck.
- 10) Inspect the top of the filter for material.  
**NOTE:** The presence of material in this area or in the exhaust is often the result of a misaligned seal or damaged filter. Consult your representative if either is the case.
- 11) Remove the filter housing spacer assembly making sure to disconnect the ground wire via push on terminal.
- 12) Turn the filter housing spacer assembly over on a table then carefully work the filter off the filter shaker insert.

# **FILTER INSTALLATION**

- 1) Turn the filter housing spacer assembly over on a table then fit the filter over the filter shaker insert.
- 2) Make sure each pleat is fully supported and the ground wire is on the filter side of the assembly.
- 3) Connect the filter housing spacer assembly ground wire to the base via the push-on terminal.
- 4) Seat the filter housing spacer assembly on the base oriented as it was removed.
- 7) Connect the motor deck ground wire to the preceding assembly then seat the deck on the preceding housing spacer.
- 9) Turn the machine **ON** and block the inlet with a flat and rigid material to place the machine under vacuum pressure.
- 10) Secure all of the housing-components then turn the machine **OFF**.

## **MOTOR BRUSH INSPECTION**

- 1) Turn the Vacuum OFF and disconnect the power source.
- 2) Remove the motor deck socket truss screws.
- 3) Remove the silencer hood assembly.
- 4) Remove the 4 metal motor-cap retaining clips using a standard bit screwdriver.
- 5) Carefully dislodge the plastic motor cap via the built-in hooks on both sides of each motor brush using a standard screwdriver.  
**Note:** Dislodge one side of a cap first, then the other.
- 6) Remove the motor brush retainers via the 2 phillips screws per brush.
- 7) Remove each of the brushes and inspect for excessive or uneven wear.  
**NOTE:** A brush should be replaced if its length is less than 0.25 inches.
- 8) Reverse the procedure to install each brush.
- 9) Replace the silencer hood making sure the switch mount fits into the slot in the silencer hood.
- 10) Secure the silencer hood with the 4 socket truss screws.

## **WARRANTY & REGISTRATION**

We warrantee to the original purchaser this vacuum cleaner against defects in material and workmanship for a period of 1 year, motor and fiberglass tank 2 years from the date of delivery. Please note the following conditions pertaining to this warranty.

- 1) Applies only to the original owner and is not transferable.
- 2) Machine will not have been dismantled or tampered with in any way.
- 3) Normal wear items will be warranted from manufacturing defects for up to 90 days from date of purchase including the following items, but not limited to:

Accessories; Belts; Bearings; Capacitors; Carbon Brushes; Casters; Electric Cords; Finishes; Filters; Floats; Switches; and the like.

4) This warranty does not apply to any repair arising by reason of misuse, neglect, abuse, or to proprietary parts.

5) This warranty is in lieu of and excludes every condition or warranty not herein expressly set out and all liability for any form of consequential loss or damage is hereby expressly excluded.

6) This Warranty is limited to repair or replacement of covered components and reasonable labor expenses.

### **Warranty Registration:**

It is purchaser's responsibility to fill out the warranty card included in the manual package and mail it to Onfloor®. This will register your purchase and start your warranty. Failure to send us this card in one week upon receipt of the machine may void the warranty.

# GROUNDING INSTRUCTIONS



## DANGER:

Improper use of the grounding plug can result in a risk of electric shock.

Electrical equipment must be grounded. If it should malfunction or breakdown, grounding provides a path of least resistance for electrical current to reduce the risk of electric shock. This vacuum is equipped with a cord having an equipment-grounding conductor and grounding plug. The plug must be inserted into an appropriate outlet that is properly installed and grounded in accordance with all local codes and ordinances.

If repair or replacement of the cord or plug is necessary, **DO NOT** connect the grounded wire to either flat blade terminal. The wire with insulation having an outer surface that is green with or without yellow stripes is the grounding wire.

## GROUNDING METHOD

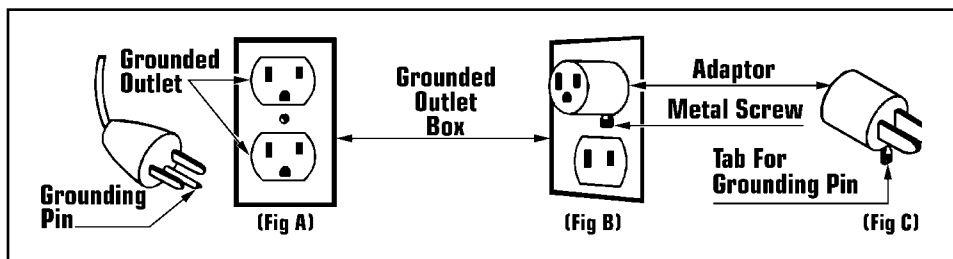

This electric equipment is for use on a nominal 120 volt circuit, and has a grounded plug that looks like the plug illustrated in (Fig A). A temporary adaptor that looks like the adaptor illustrated in (Fig B & C) may be used to connect this plug to a 2-pole receptacle as shown in (Fig B) if a properly grounded outlet is not available.

The temporary adaptor should be used only until a properly grounded outlet (Fig A) can be installed by a qualified electrician. The green color rigid ear, lug or the like extending from the adaptor must be connected to a permanent ground such as a properly grounded outlet box cover. Whenever the adaptor is used, it must be held in place by a metal screw. (Fig C)



## WARNING:

Improper connection of the equipment-grounding conductor can result in a risk of electric shock. Check with a qualified electrician or service person if you are in doubt as to whether the outlet is properly grounded.

**DO NOT** modify the plug provided with the equipment. If it will not fit the outlet, have a proper outlet installed by a qualified electrician.

**Note:** In Canada, the use of a temporary adaptor is not permitted by the Canadian Electrical Code.

# PARTS DRAWING AND PARTS LIST

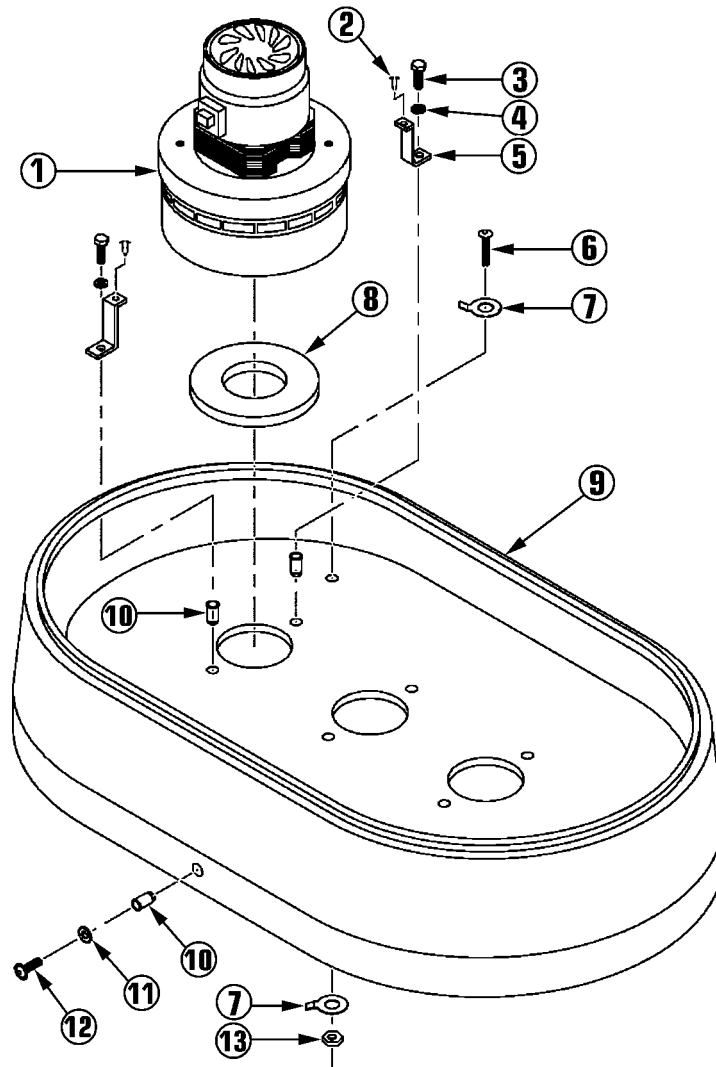

## Blue WS Motor Assembly 2220

## Blue WS Motor Assembly 2320

Ref No	Part Description	Qty	Part No
1a	120V, 1000 Watt Motor	2	232645
1b	240V, 1200 Watt Motor	2	458929
2	#8 x 1/2" Phil Pan Head	4	232653
3	M6 x 25 Hex Cap	4	232807
4	M6 Split Lock Washer	4	464023
5	WS Motor Hold Down Bracket	4	232793
6	M6 x 20 ULS Allen Head Screw	1	464155
7	Ground Connection	2	232904
8	Neoprene Sponge Gasket	2	232912
9	Blue WS Motor Deck	1	232971
10	M6 Blind Pem	6	463825
11	1/4" External Star Washer	2	464104
12	M6 x 25 Allen Head Screw	2	464112
13	M6 Lock Nut	1	464090

Ref No	Part Description	Qty	Part No
1a	120V, 800 Watt Motor	3	459003
1b	240V, 1200 Watt Motor	3	458929
2	#8 x 1/2" Phil Pan Head	6	232653
3	M6 x 25 Hex Cap	6	232807
4	M6 Split Lock Washer	6	464023
5	WS Motor Hold Down Bracket	6	232793
6	M6 x 20 ULS Allen Head Screw	1	464155
7	Ground Connection	2	232904
8	Neoprene Sponge Gasket	3	232912
9	Blue WS Motor Deck	1	232971
10	M6 Blind Pem	8	463825
11	1/4" External Star Washer	2	464104
12	M6 x 25 Allen Head Screw	2	464112
13	M6 Lock Nut	1	464090

# PARTS DRAWING AND PARTS LIST

## Inlet

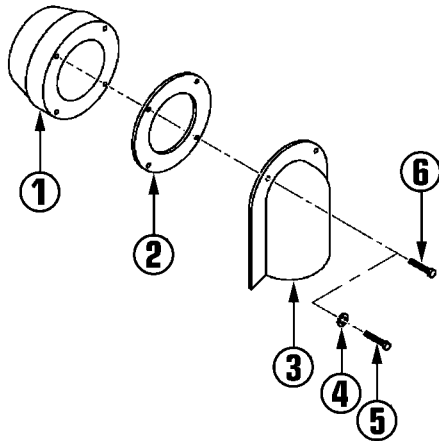

## Inlet

Ref No	Part Description	Qty	Part No
1	50MM GFK Black Plastic Inlet	1	232696
1a	50MM Aluminum Inlet	1	232475
1b	70MM Aluminum Inlet	1	232661
1c	100MM Aluminum Inlet	1	35188
2a	50MM Inlet Gasket	1	232823
2b	70MM Inlet Gasket	1	232785
2c	100MM Inlet Gasket	1	34918
3a	50MM Metal Inlet Deflector	1	232491
3b	70MM Aluminum Deflector	1	232688
3c	100MM Aluminum Deflector	1	35189
4a	M4 Star Locking Washer	1	232505
4b	M5 Ext. Tooth Lock Washer (50 & 100 MM)	1	232734
5a	M4 x 20 Socket Cap Screw	4	232610
5b	M5- .8 x 20 Socket Cap Screw (50 & 100 MM)	1	232718
6a	#8 x 1 Phil Truss Head Screw	4	464147
6b	M5- .8 x 30 Socket Cap Screw (50 & 100 MM)	3	232726

## Dust Pan Lever Assembly

Ref No	Part Description	Qty	Part No
1	Dust Pan Lever Bearing	2	463728
2	Dust Pan Tension Lever	2	463736
3	D6 x 19MM Pin	2	463744
4	M8 x 35 Carriage Screw	2	463779
5	M8 Flat Washer	6	232831
6	M8 Hex Nut	4	463752
7	M8 Flat Washer	6	463655
8	M8 Lock Nut	4	463663
9	Flat Steel Pivot	2	463701
10	M6 Flat Washer	4	463698
11	C Spring Clip	4	463671
12	D6 x 15 Pin	2	463787
13	X 55 - 8.8 M8 Hex Bolt	2	232742
14	M8 External Washer	2	232564
15	Spacer for Foot Lever	2	232750
16	Foot Lever	1	232483

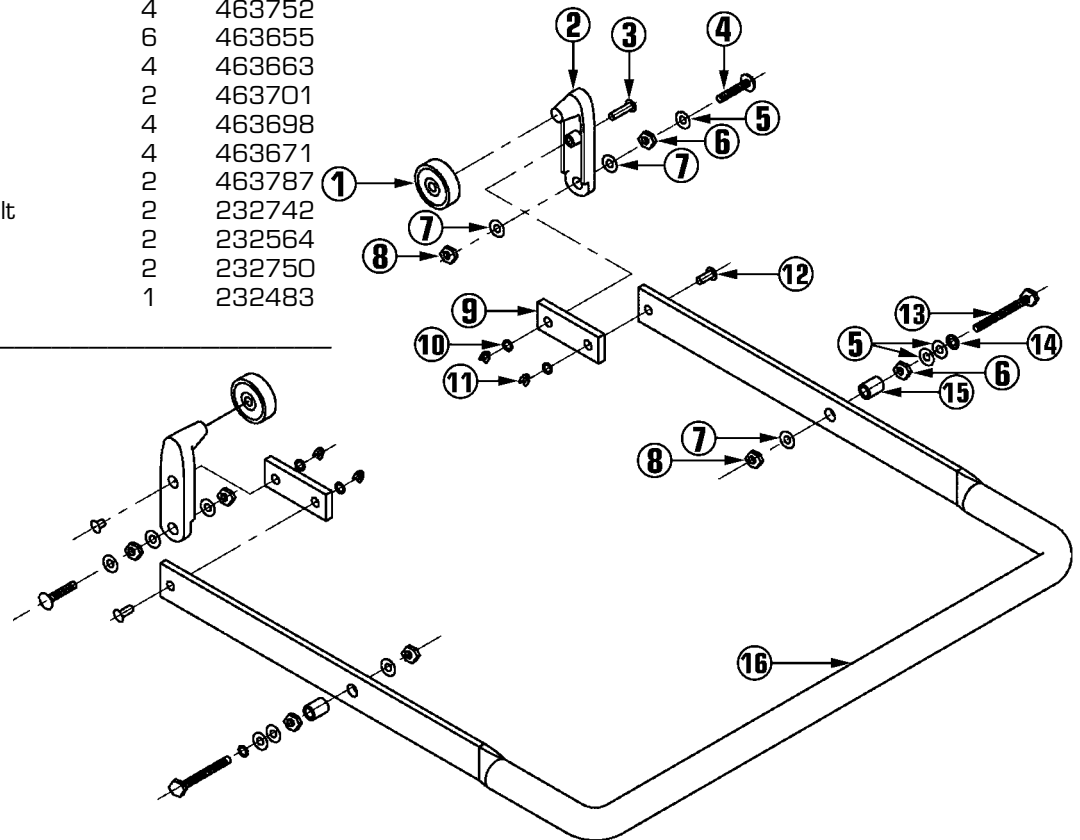

# PARTS DRAWING AND PARTS LIST

## Blue WS Diffuser Assembly

Ref No	Part Description	Qty	Part No
1	Silencer Hood	1	232467
2	M6 Blind Pem	4	463825
3	1/4" External Star Washer	4	464104
4	M6 x 25 Allen Head Screw	4	464112
5	Diffuser Mat	1	232858
6	Upper Silencer Foam Assy.	1	232866
7a	2 Motor Air Channel Plate	1	232882
7b	3 Motor Air Channel Plate	1	232890
8	Lower Foam Assy. For Motors	1	232874

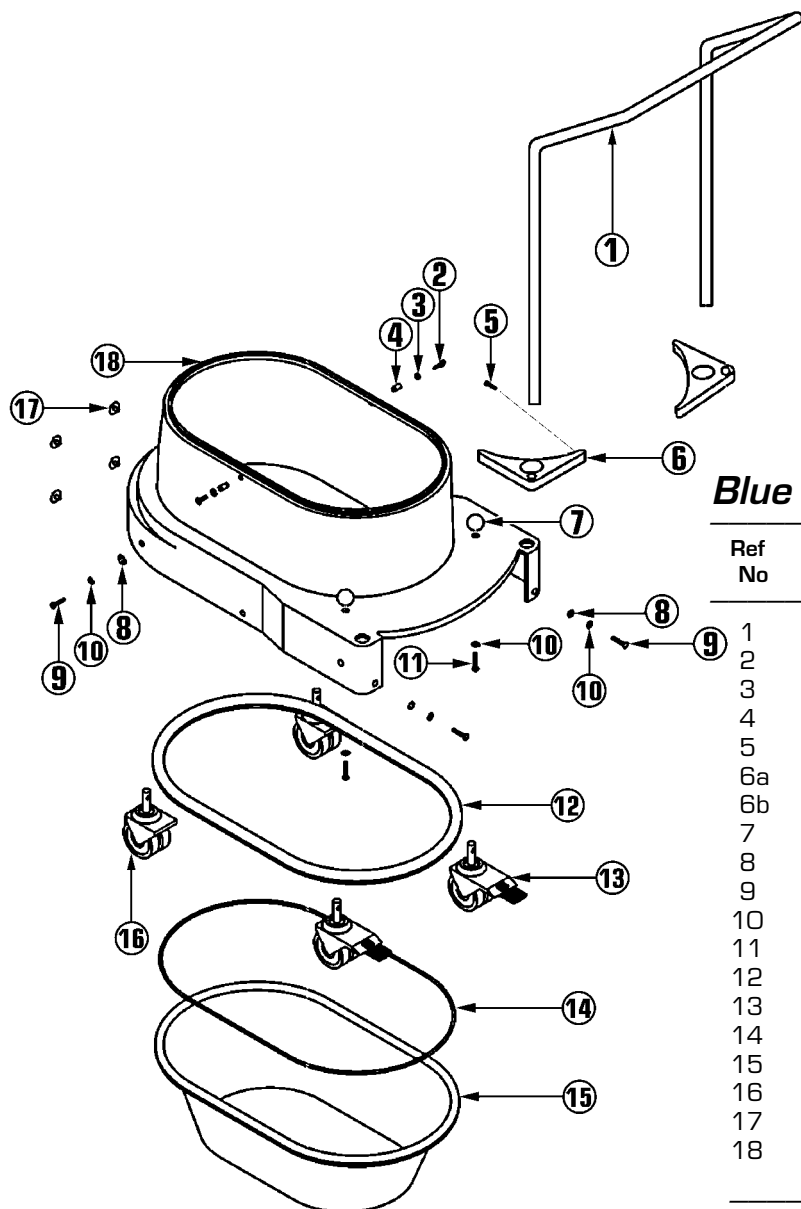
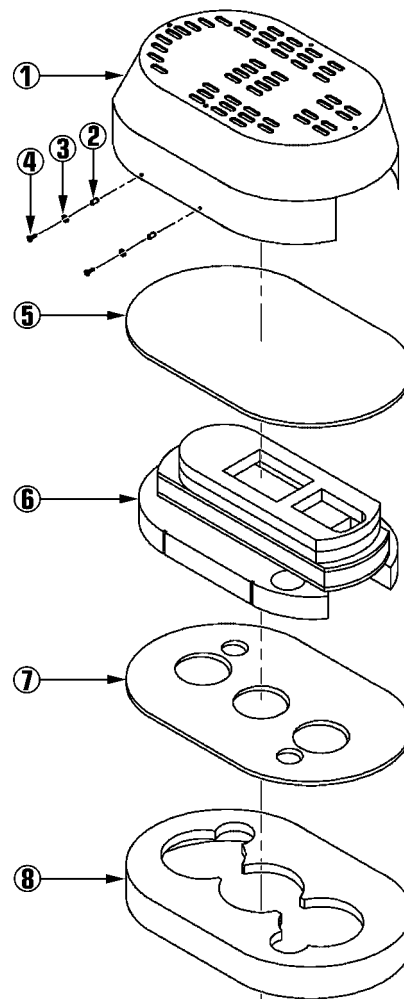

## Blue WS Base Assembly

Ref No	Part Description	Qty	Part No
1	Push Handle	1	472522
2	#8 x 1 Phil Truss Head	4	464147
3	M6 x 25 Allen Head Screw	2	464112
4	1/4" Star Washer	2	464104
5	M6 Blind Pem	2	463825
6a	Plastic Handle Support	2	464171
6b	Aluminum Handle Support	2	34809
7	8MM Black Knob	2	232629
8	M8 Flat Washer	4	232831
9	M8 x 25 Hex Bolt	4	232580
10	M8 Washer	6	232564
11	M8 1.25 x 20 Hex Cap	2	232572
12	Dust Pan/Lower Housing Gasket	1	232521
13	75MM Fixed Dual Casters w/Stud	2	232637
14	Dust Pan Replacement Gasket	1	232920
15	35LTR Blue Dust Pan	1	232769
16	75MM Swivel Double Casters	2	475572
17	8MM Black Plug	4	232556
18	Blue Lower Housing	1	232939

# PARTS DRAWING AND PARTS LIST

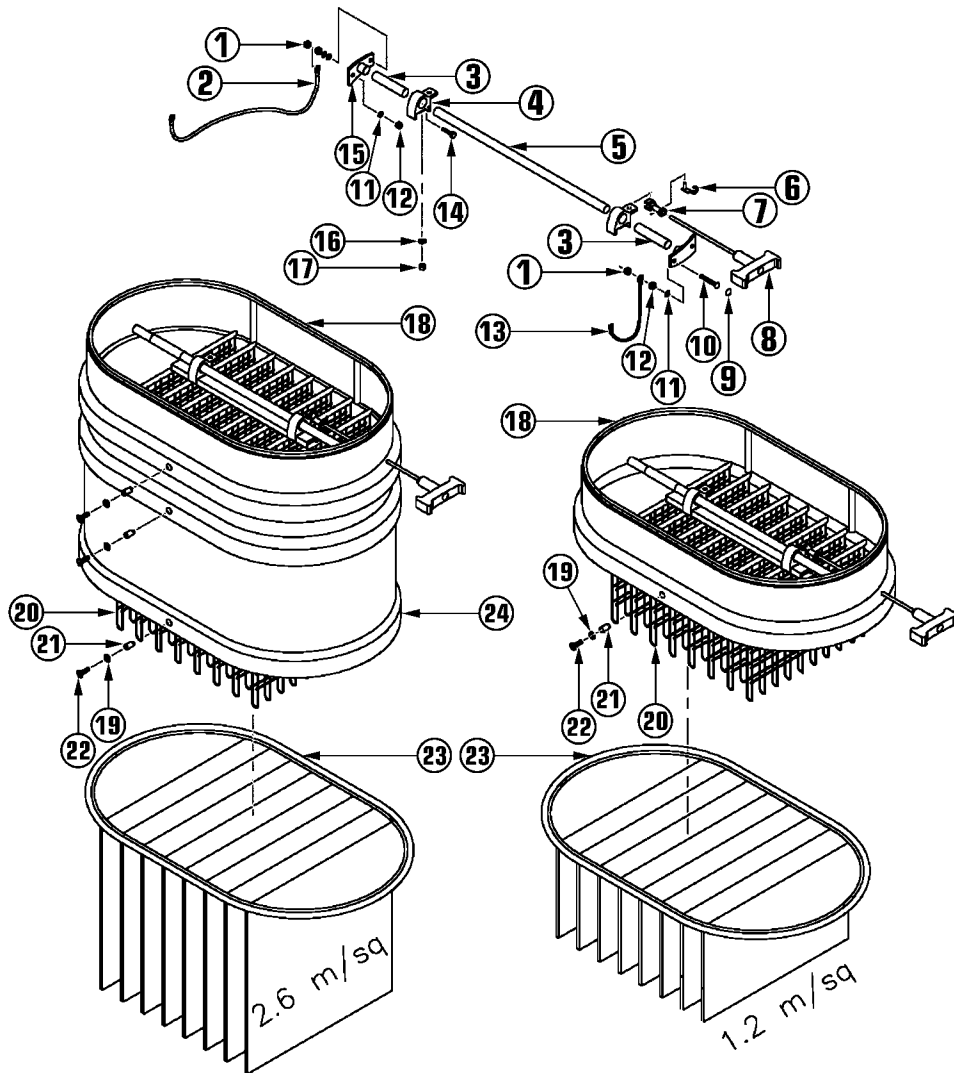

Ref No	Part Description	Qty	Part No
1	M6 Lock Nut	2	464090
2a	1.2 Filter Ground Deflector	1	232815
2b	2.6 Filter Ground Deflector	1	464074
3	3/4 ID Clear Hose	2	463949
4	Slide Assembly w/Hook	2	464058
5	Slide Bar	1	463957
6	6 x 12 Spring Clip	1	463973
7	Steel Yoke End	1	463965
8	Shaker Bar w/Swivel Handle	1	463981
9	4.5/13 Plastic Plug	4	464007
10	M6 x 30 Allen Screw Countersunk	4	464015
11	M6 Split Lock Washer	4	464023
12	M6 Hex Nut	4	232513

Ref No	Part Description	Qty	Part No
13	Ground Shaker to Motor Deck	1	464082
14	M8 1.25 x 20 Hex Cap	1	232572
15	Shaker Rod Mounting Support	2	463930
16	M8 Lock Washer	1	464031
17	N8 Hex Nut	1	463752
18	Blue Small Housing Spacer	1	232955
19	1/4" Star Washer	2	464104
20	1.2 Filter Screen Insert	1	232599
21	M6 Blind Pem	2	463825
22	M6 x 25 Allen Head Screw	2	464112
23a	1.2 M2 13SQ/FT Filter	1	458864
23b	2.6 M2 28SQ/FT Filter	1	464120
24	Large Blue Housing Spacer	1	232947

# **TROUBLE SHOOTING GUIDE**

## **CAUTION:**

Always disconnect power cord before servicing the vacuum.

### **PROBLEM: Insufficient Vacuum Pressure.**

#### **POSSIBLE CAUSE:**

1. Motors are not **ON** and/or working.
2. Dustpan improperly seated.
3. Filter clogged or improperly seated.
4. Clogged hose.
5. Unit is improperly sealed.

#### **POSSIBLE SOLUTION:**

1. Turn motors **ON**, and check motor brushes
2. Remove collection pan, inspect seal, and replace.
3. Follow filter inspection/cleaning procedure (page 6).
4. Remove hose and re-inspect vacuum pressure, if vacuum pressure returns to normal, snake hose.
5. Block the inlet with a flat and rigid material to place the unit under vacuum pressure then inspect for air leaks.

### **PROBLEM: Air Leak**

#### **POSSIBLE CAUSE:**

1. Worn or poorly seated seals, retainers improperly installed

#### **POSSIBLE SOLUTION:**

1. Block the inlet with a flat and rigid material to place the unit under vacuum pressure then remove retainers and turn the unit **OFF**. Inspect the seals for completeness, then reseal and secure components again under vacuum pressure.

### **PROBLEM: Material In Exhaust On Top Side of Filter.**

1. Poor filter seal or torn filter.

1. Follow filter inspection procedure on pg 6.

### **PROBLEM: Unusual or High Pitched Noises**

1. Motor bearings or motor bushings.
2. Worn or poorly seated seals. Retainers improperly installed

1. Follow relevant motor bushing inspection procedure, pg 6. Check motor bearings for noise by hand.
2. Block the inlet with a flat and rigid material to place the unit under vacuum pressure then remove retainers and turn the unit **OFF**. Inspect the seals for damage, then reseal and secure components again under vacuum pressure.

## **WARNING:**

Repairs should only be performed by an authorized service center.



Address: 777 South Street, P.O. Box 2310, Newburgh, New York 12550-0606  
TEL: 877.356.6703 / 845.565.6623 / FAX: 845.565.8894  
Internet Address: [www.onfloor.com](http://www.onfloor.com) / [info@onfloor.com](mailto:info@onfloor.com)